

4.3.2 Mathematics Alternative A Paper 2 (121/2)

1.	Limits: 12.5 ± 0.05 m and 9.23 ± 0.005 m Maximum difference $= 12.55 - 9.225$ $= 3.325$ m	B1																			
		M1 A1 3																			
2.	a) First 6 terms -7, -4, -1, 2, 5, 8 b) Sum of 1 st 50 terms $S_{50} = \frac{50}{2}\{2 \times -7 + 49 \times 3\}$ $= 3325$	B1																			
		M1 A1 3																			
		3																			
3.	a) $\angle BAC = 70^\circ - 30^\circ = 40^\circ$ Reflex $\angle BOC = 360^\circ - 80^\circ$ $= 280^\circ$ b) $\angle ACO = 40^\circ - 30^\circ = 10^\circ$	B1																			
		B1 B1 3																			
		3																			
4.	$L = \frac{kM}{N^2}$ $2 = \frac{k \times 12}{36}$ $k = 6$ \therefore equation $L = \frac{6M}{N^2}$	B1																			
		M1 A1 3																			
		3																			
5.	<table border="1"> <thead> <tr> <th>Marks</th> <th>Frequency</th> <th>c.f</th> </tr> </thead> <tbody> <tr> <td>1 - 10</td> <td>2</td> <td>2</td> </tr> <tr> <td>11 - 20</td> <td>4</td> <td>6</td> </tr> <tr> <td>21 - 30</td> <td>11</td> <td>17</td> </tr> <tr> <td>31 - 40</td> <td>5</td> <td>22</td> </tr> <tr> <td>41 - 50</td> <td>3</td> <td>25</td> </tr> </tbody> </table>	Marks	Frequency	c.f	1 - 10	2	2	11 - 20	4	6	21 - 30	11	17	31 - 40	5	22	41 - 50	3	25	B1 for c.f	
	Marks	Frequency	c.f																		
	1 - 10	2	2																		
	11 - 20	4	6																		
	21 - 30	11	17																		
31 - 40	5	22																			
41 - 50	3	25																			
Median																					
$= 20.5 + \frac{12.5 - 6}{11} \times 10$																					
$= 20.5 + 5.91$																					
$= 26.41$																					
$\simeq 26$																					
	M1 M1 A1 4																				

6.	Amplitude = 2 Period = $\frac{360}{3} = 120^\circ$	B1 B1 <hr/> 2	
7.	Area scale factor = $\frac{30}{5} = 6$ $4x - 2x + 2 = 6$ $2x = 4$ $x = 2$	B1 M1 A1 <hr/> 3	
8.	$(3 - x)^7 = 3^7 - 7(3)^6x + 21(3)^5x^2 - 35(3)^4x^3 + 35(3)^3x^4 + \dots$ $= 2187 - 5103x + 5103x^2 - 2835x^3 + 945x^4$ $(2.8)^7 = (3 - 0.2)^7$ $= 2187 - 5103(0.2) + 5103(0.2)^2 - 2835(0.2)^3 + 945(0.2)^4$ $= 1349.352$	B1 M1 A1 <hr/> 3	
9.	$\text{Log} \frac{15^2}{x} = \log 5(x - 4)$ $\frac{15^2}{x} = 5(x - 4)$ $x^2 - 4x - 45 = 0$ $(x - 9)(x + 5) = 0$ $x = 9 \text{ or } -5$ $x = 9$	M1 M1 M1 A1 <hr/> 4	
10.	$PR = \sqrt{60^2 + 11^2} = 61$ $\text{Tan } \theta = \frac{10}{61}$ $\theta = 9.31^\circ$	B1 M1 A1 <hr/> 3	

11.	$3x - y = 9 \quad \dots \times x$ $x^2 - xy = 4$ $3x^2 - xy = 9x$ $\frac{x^2 - xy = 4}{2x^2} = 9x - 4$ $2x^2 - 9x + 4 = 0$ $(2x - 1)(x - 4) = 0$ $x = \frac{1}{2} \quad \text{or} \quad x = 4$ $y = 3\left(\frac{1}{2}\right) - 9 \quad \text{or} \quad 3(4) - 9$ $= -7\frac{1}{2} \quad \text{or} \quad 3$	M1 M1 A1 B1 4	Attempt to solve Factors
12.	$\left(1 + \frac{r}{100}\right)^4 = \frac{495000}{280000}$ $1 + \frac{r}{100} = 1.153$ $r = 15.3$	M1 M1 A1 3	
13.	$8008 = \frac{40 + \theta}{360} \times 2 \times \frac{22}{7} \times 6370$ $40 + \theta = \frac{8008 \times 360 \times 7}{2 \times 22 \times 6370} = 72$ $\theta = 72^\circ - 40^\circ$ $= 32^\circ$ <p>Position of B(32° S, 20°W)</p>	M1 M1 A1 3	or 32° seen
14.	$\underline{r} + \underline{s} = (7\underline{i} + 2\underline{j} - \underline{k}) + (-\underline{i} + \underline{j} - \underline{k})$ $= 6\underline{i} + 3\underline{j} - 2\underline{k}$ $ \underline{r} + \underline{s} = \sqrt{6^2 + 3^2 + (-2)^2}$ $= 7$	B1 M1 A1 3	

15.	$y = \int (x^2 - 4x + 3) dx$ $= \frac{1}{3}x^3 - 2x^2 + 3x + c$ $0 = \frac{1}{3} - 2 + 3 + c$ $\therefore c = -\frac{4}{3}$ $\therefore y = \frac{1}{3}x^3 - 2x^2 + 3x - \frac{4}{3}$	<p>M1</p> <p>M1</p> <p>A1</p>	
		3	
16.	<p>Temperature at the 2nd minute = 60° Temperature at the 11th minute = 18°</p> <p>Average rate of cooling</p> $= \frac{60 - 18}{2 - 11}$ $= \frac{42}{ 9 }$ $= 4\frac{2}{3} \text{ C/min}$	<p>B1</p> <p>M1</p> <p>A1</p>	for both ✓
		3	
17.	<p>a) $A = \frac{3}{4}B, C = 2B$</p> $\Rightarrow A:B:C = \frac{3}{4}B:B:2B$ $= 3:4:8$ <p>b) $\left(\frac{168}{8} \times 4\right)$ litres</p> $= 84 \text{ l}$ <p>c) (i) $\frac{3 \times 160 + 4 \times 205 + 8 \times 100}{3 + 4 + 8}$</p> $= \text{Ksh } 140$ <p>(ii) $\frac{182 - 140}{140} \times 100\%$</p> $= 30\%$ <p>(iii) $\text{Ksh } 140 \times \frac{125}{100}$</p> $= \text{Ksh } 175$	<p>M1</p> <p>A1</p> <p>M1</p> <p>A1</p> <p>M1</p> <p>A1</p> <p>M1</p> <p>A1</p>	
		10	

18.	<p>a) (i) $(50 + 40)(50) = 30(30 + x)$ $4500 = 900 + 30x$ $30x = 3600$ $QS = x = 120 \text{ cm}$</p> <p>(ii) $RS = \frac{1}{2}QS$ $= \frac{1}{2}(120) = 60 \text{ cm}$ $OR = \sqrt{61^2 - 60^2}$ $= 11 \text{ cm}$</p> <p>b) (i) $\sin \theta = \frac{60}{61}$ $\theta = 79.6^\circ$</p> <p>(ii) Angle at the centre $= 2 \times 79.6$ $= 159.2^\circ$</p> <p>Length of minor arc QS $= \frac{159.2}{360} \times 2\pi \times 61$ $= 169.5 \text{ cm}$</p>	<p>M1</p> <p>A1</p> <p>B1</p> <p>M1</p> <p>A1</p> <p>M1</p> <p>A1</p> <p>M1</p> <p>A1</p> <p>M1</p> <p>A1</p> <p>10</p>	<p>or equivalent</p>
19.	<p>a) (i) $38392 + 2108$ $= \text{Ksh } 41000$</p> <p>(ii) $10164 \times 0.1 + 9576 \times 0.15 + 9576 \times 0.2$ $+ 9576 \times 0.25 + 2108 \times 0.3$ $= 1016.4 + 1436.4 + 1915.2 + 2394 + 632.4$ $= \text{Ksh } 7394.4$</p> <p>monthly income tax $= 7394.4 - 1162$ $= \text{Ksh } 6232.4$</p> <p>b) Amount saved in coop society $= \frac{5}{100} \times (41000 - 15000)$ $= \text{Ksh } 1300$</p> <p>Nett pay $41000 - (6232.4 + 1300)$ $= \text{Ksh } 33467.6$</p>	<p>M1</p> <p>A1</p> <p>M1</p> <p>M1</p> <p>M1</p> <p>A1</p> <p>B1</p> <p>M1</p> <p>M1</p> <p>A1</p> <p>10</p>	<p>$\sqrt{1^{\text{st}}}$ band</p> <p>$\sqrt{3}$ middle bands</p> <p>$\sqrt{\text{last } (5^{\text{th}})}$ band</p>

20. a) $y > x$
 $y \leq 2x$

$x + y < 20$
 $x + y > 8$

B1
 B1

B1
 B1

b) (i)

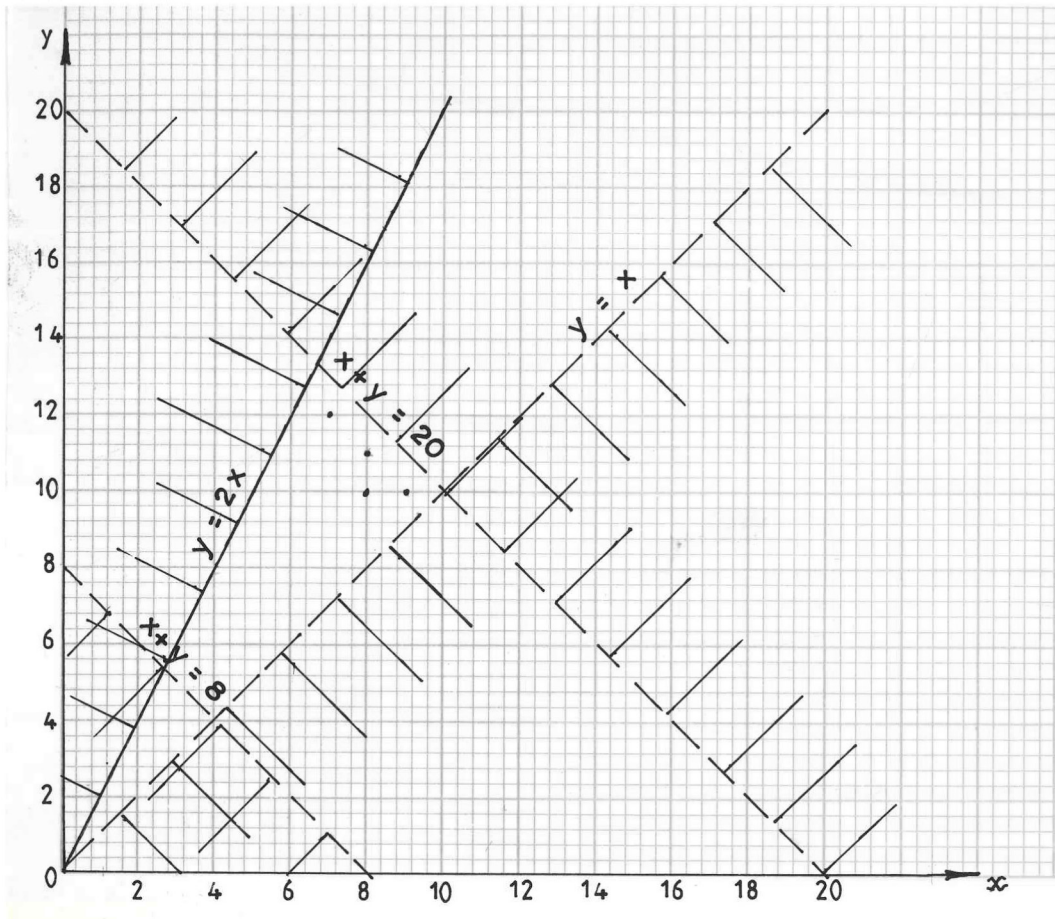

(ii) Maximum area:

$$9 \times 10 = 90 \text{ m}^2$$

B1 line $y = 2x$ and $\sqrt{\quad}$ shading
 B1 broken line $x + y = 20$ and $\sqrt{\quad}$ shading
 B1 broken line $x + y = 8$ and $\sqrt{\quad}$ shading
 B1 broken line $y = x$ and $\sqrt{\quad}$ shading

M1
 A1

10

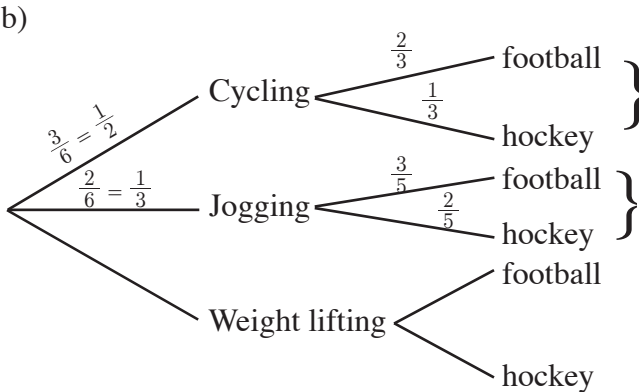
21.	<p>a) (i) $\frac{3}{6} + \frac{1}{6}$ $= \frac{2}{3}$</p> <p>(ii) $\frac{2}{6} \times \frac{2}{6}$ $= \frac{1}{9}$</p> <p>b)</p>  <p>c) (i) P(Gataro plays football) $= \frac{1}{2} \times \frac{2}{3} + \frac{1}{3} \times \frac{3}{5} + \frac{1}{6} \times \frac{1}{2}$ $= \frac{37}{60}$</p> <p>(ii) P(neither jogs nor plays football) $= \frac{1}{2} \times \frac{1}{3} + \frac{1}{6} \times \frac{1}{2}$ $= \frac{1}{4}$</p>	<p>M1</p> <p>A1</p> <p>M1</p> <p>A1</p> <p>B1</p> <p>B1</p> <p>M1</p> <p>A1</p> <p>M1</p> <p>A1</p>	
		10	

22.	<p>a) (i) $\underline{BA} = \underline{a} - \underline{b}$</p> <p>(ii) $\underline{BN} = \frac{1}{3}\underline{BA} = \frac{1}{3}(\underline{a} - \underline{b})$</p> <p>(iii) $\underline{ON} = \underline{b} + \frac{1}{3}(\underline{a} - \underline{b})$ $= \frac{1}{3}\underline{a} + \frac{2}{3}\underline{b}$</p> <p>b) $\underline{BX} = h\underline{BM} = h\left(\frac{1}{2}\underline{a} - \underline{b}\right)$ $\underline{OX} = k\underline{ON} = k\left(\frac{1}{3}\underline{a} + \frac{2}{3}\underline{b}\right)$ also $\underline{OX} = \underline{OB} + \underline{BX}$ $= \underline{b} + h\left(\frac{1}{2}\underline{a} - \underline{b}\right)$</p> <p>$k\left(\frac{1}{3}\underline{a} + \frac{2}{3}\underline{b}\right) = \underline{b} + h\left(\frac{1}{2}\underline{a} - \underline{b}\right)$ $\frac{1}{3}k\underline{a} = \frac{1}{2}h\underline{a}$ $\frac{1}{3}k = \frac{1}{2}h \implies k = \frac{3}{2}h \dots\dots\dots (i)$ $\frac{2}{3}k\underline{b} = \underline{b} - h\underline{b}$ $\frac{2}{3}k = 1 - h \dots\dots\dots (ii)$</p> <p>Substituting $k = \frac{3}{2}h$ in (ii)</p> <p>$\frac{2}{3}\left(\frac{3}{2}h\right) = 1 - h \implies h = \frac{1}{2}$</p> <p>Substituting $h = \frac{1}{2}$ in (i)</p> <p>$k = \frac{3}{2}\left(\frac{1}{2}\right) = \frac{3}{4}$</p>	<p>B1</p> <p>B1</p> <p>M1</p> <p>A1</p> <p>B1</p> <p>B1</p> <p>M1</p> <p>M1</p> <p>M1</p> <p>A1</p> <p>10</p>	<p>for $h = \frac{1}{2}$ and $k = \frac{3}{4}$</p>
-----	--	---	--

23.

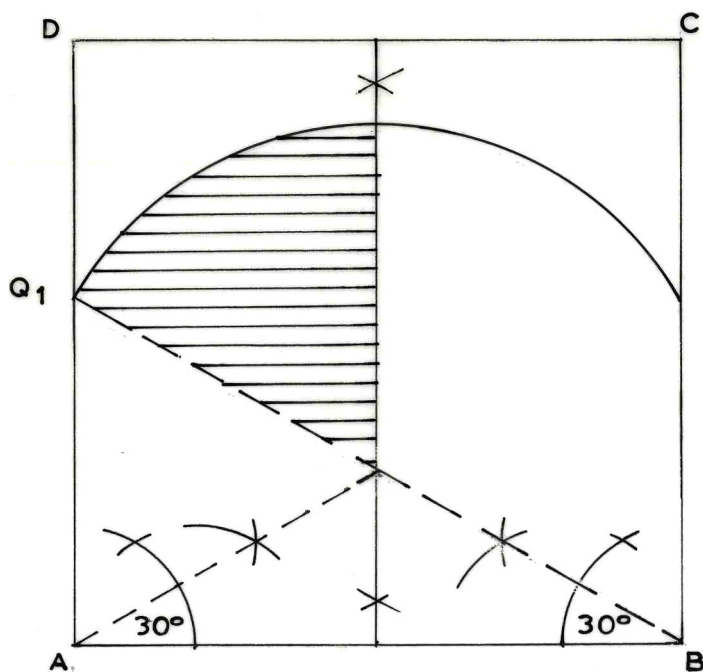

- (i)
- (ii)

b) (i) $9.2 \times 10 = 92 \text{ m}$

(ii) area of region bounded by locus of P,
 locus of Q and line BQ₁
 angle = 60° radius = 46 m
 $= \pi \times 46^2 \times \frac{60}{360}$
 $= 1107.94$
 $\approx 1108 \text{ m}^2$

B2	locus of P
B1	construction of 30°
B1	identification of centre
B1	drawing of arc
B1	
B1	Identifying region
B1	for radius and angle of sector
M1	
A1	
10	

24. a)

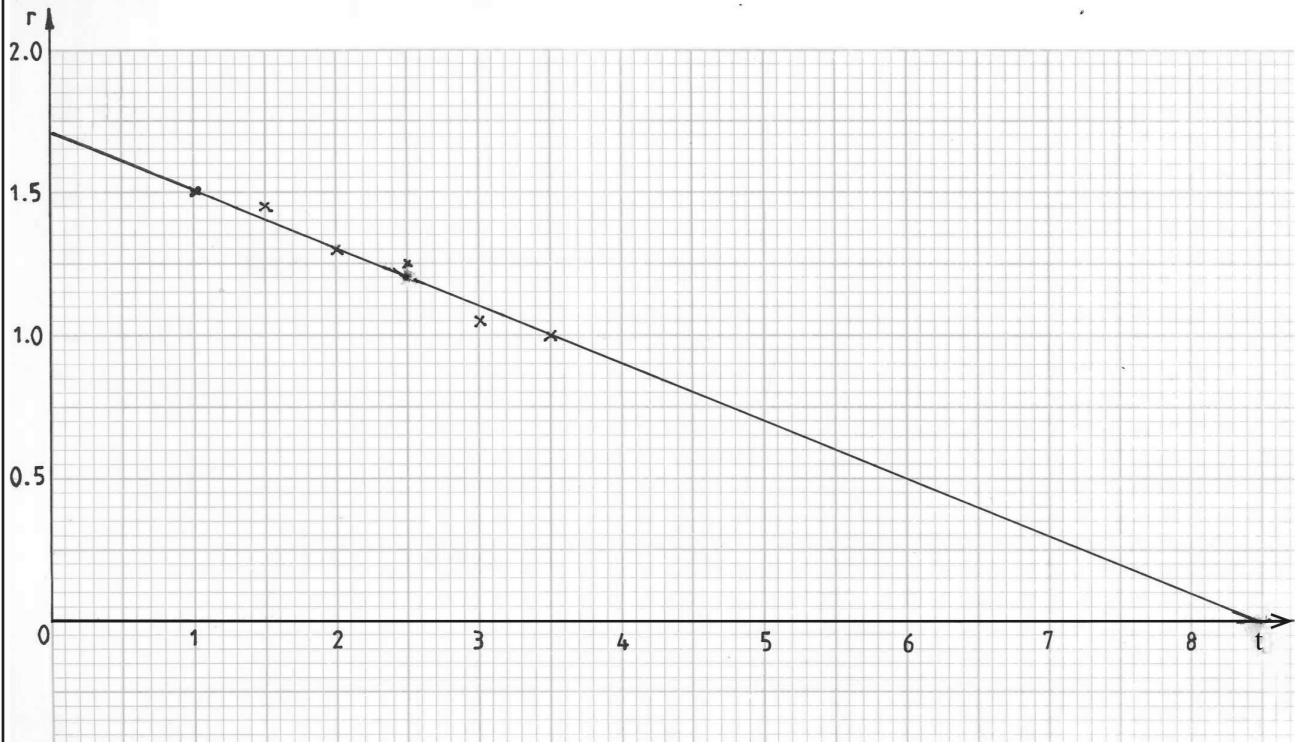

b) (i) value of a

$$= \frac{-0.7}{3.5}$$

$$= -0.2$$
 value of k = 1.7

(ii) equation: $r = -0.2t + 1.7$

(iii) value of t when $r = 0$
 $\therefore 0 = -0.2t + 1.7$
 $0.2t = 1.7$

$$t = \frac{1.7}{0.2} = 8.5$$

S1 \checkmark scale
 P2 (P1 for 4 points \checkmark plotted)
 L1 \checkmark line
 M1

A1
 B1

B1

M1

A1

10

4.3.3 Mathematics Alternative B (122/1)

1.	$\frac{-8 \times +2 + -11}{+18 \div -2 \times +3} = \frac{-27}{-27}$ $= 1$	M1 A1 2	
2.	Number of boys = $630 - 84$ $= 546$ Number of students = $630 + 546$ $= 1176$ Number of parents = $1176 \div 4$ $= 294$	M1 M1 A1 3	
3.	$3(78 - y) + 5y = 300$ $2y = 66$ $y = 33$ $\therefore x = 78 - 48 = 45$ $10x + 15y = 450 + 495 = 945$	M1 A1 B1 3	
4.	(a) $96 = 2^5 \times 3$ $84 = 2^2 \times 3 \times 7$ $36 = 2^2 \times 3^2$ GCD of 96, 84 and 36 = $2^2 \times 3 = 12$ (b) Number of packets of foodstuffs $= \frac{96}{12} + \frac{84}{12} + \frac{36}{12}$ $= 8 + 7 + 3 = 18$	M1 A1 M1 A1 4	or equivalent
5.	$\frac{128}{2^5 \div 2^8} = \frac{2^7}{2^{-3}}$ $= 2^{10}$	B1 B1 B1 3	$\sqrt{\text{numerator}}$ $\sqrt{\text{denominator}}$

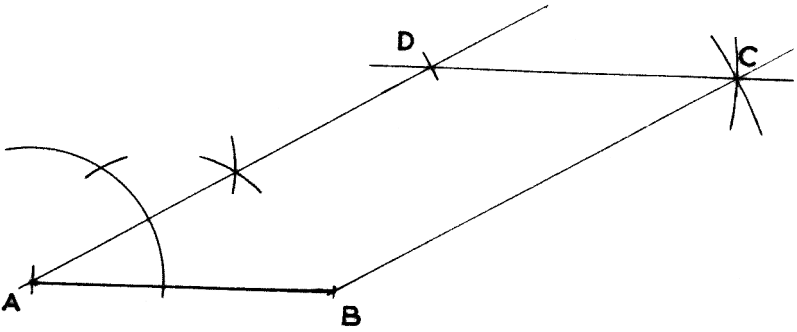
6.		<table border="1"> <tbody> <tr> <td>B1</td> <td>✓ construction of 30°</td> </tr> <tr> <td>B1</td> <td>✓ construction of AD = 6 cm</td> </tr> <tr> <td>B1</td> <td>identifying C and completing parallelogram</td> </tr> <tr> <td>3</td> <td></td> </tr> </tbody> </table>	B1	✓ construction of 30°	B1	✓ construction of AD = 6 cm	B1	identifying C and completing parallelogram	3	
B1	✓ construction of 30°									
B1	✓ construction of AD = 6 cm									
B1	identifying C and completing parallelogram									
3										
7.	$4\alpha + \alpha + 10 = 90^\circ$ $5\alpha = 80^\circ$ $\alpha = 16^\circ$ $\sin \alpha = 0.276$	<table border="1"> <tbody> <tr> <td>M1</td> <td></td> </tr> <tr> <td>A1</td> <td></td> </tr> <tr> <td>B1</td> <td></td> </tr> <tr> <td>3</td> <td></td> </tr> </tbody> </table>	M1		A1		B1		3	
M1										
A1										
B1										
3										
8.	$\frac{0.375 \div 0.06 - 4.2}{3.96 + 2.8 \times 0.05} = \frac{6.25 - 4.2}{3.96 + 0.14}$ $= \frac{2.05}{4.1}$ $= 0.5$	<table border="1"> <tbody> <tr> <td>M1</td> <td>Evidence of division and multiplication should be seen.</td> </tr> <tr> <td>M1</td> <td></td> </tr> <tr> <td>A1</td> <td></td> </tr> <tr> <td>3</td> <td></td> </tr> </tbody> </table>	M1	Evidence of division and multiplication should be seen.	M1		A1		3	
M1	Evidence of division and multiplication should be seen.									
M1										
A1										
3										
9.	<p>Mangoes: $2x + x + \frac{1}{3}x$</p> $= 3\frac{1}{3}x$ <p>Oranges: $\frac{1}{3}y + y + \frac{2}{3}y = 2y$</p> <p>Total Fruits = $3\frac{1}{3}x + 2y$</p>	<table border="1"> <tbody> <tr> <td>M1</td> <td></td> </tr> <tr> <td>M1</td> <td></td> </tr> <tr> <td>A1</td> <td></td> </tr> <tr> <td>3</td> <td></td> </tr> </tbody> </table>	M1		M1		A1		3	
M1										
M1										
A1										
3										

13.	$2x^2 + 6y - 3x - 4xy$ $= 2x^2 - 4xy - 3x + 6y$ $= 2x(x - 2y) - 3(x - 2y)$ $= (2x - 3)(x - 2y)$	M1 A1 2	or equivalent
14.	$x^2 \sin 30^\circ = 34$ $x = \sqrt{\frac{34}{\sin 30}}$ $\simeq 8 \text{ cm}$	M1 M1 A1 3	

15.

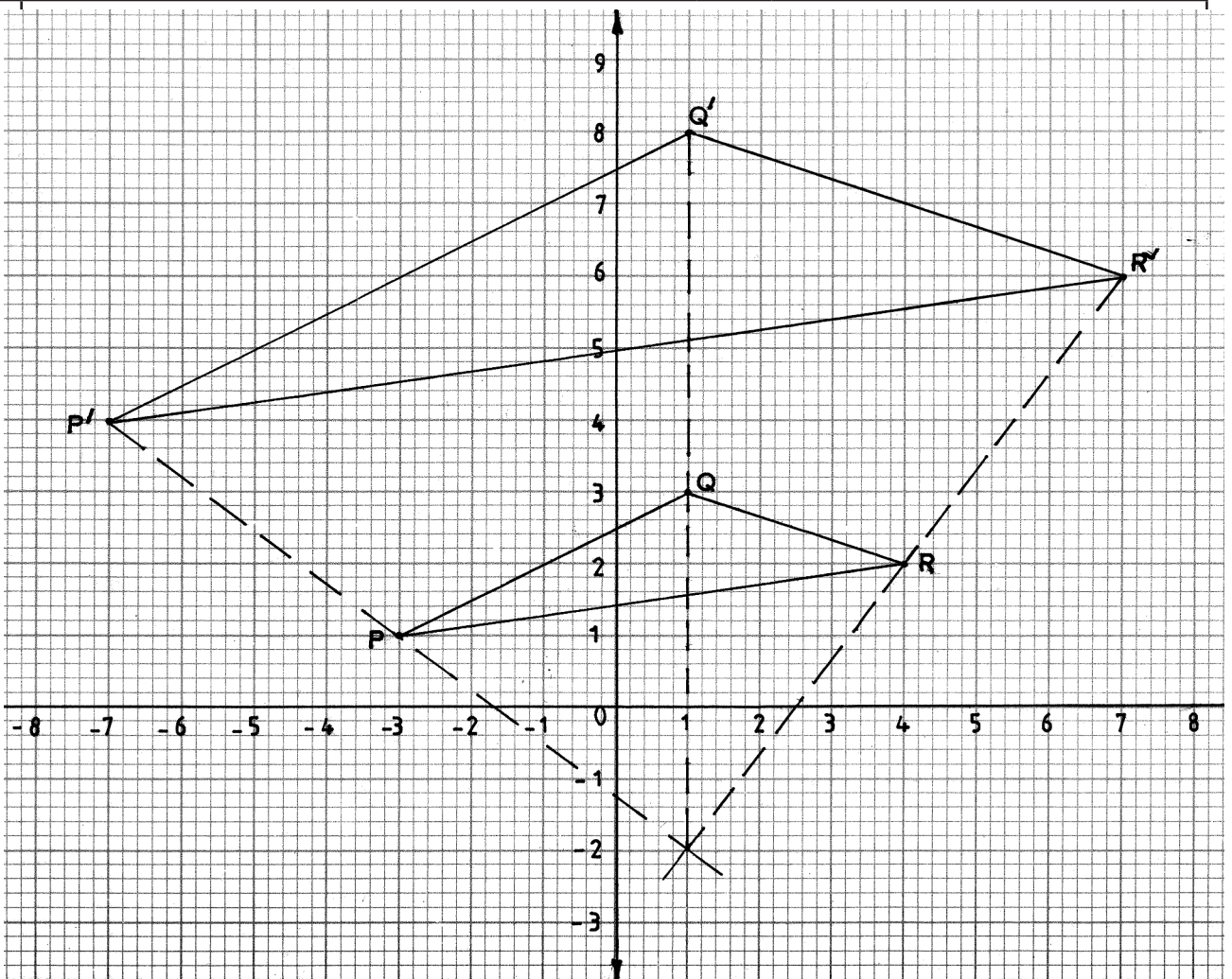

- (a) $\triangle PQR$
 $\triangle P'Q'R'$
 (b) Centre of enlargement $(1, -2)$
 Scale factor of enlargement $= \frac{10}{5} = 2$

B1
 B1
 B1
 B1

4

16. $\frac{L}{2.1} = \frac{L+5}{3.5}$

$3.5L - 2.1L = 10.5$

$L = 7.5$

$L = 5 + 7.5 = 12.5$

Curved area

$= \frac{22}{7} \times (3.5 \times 12.5 - 2.1 \times 7.5)$

$= 88 \text{ cm}^2$

M1

M1 for area
 M1 for difference

A1

4

17.	(a) (i)	Mumo's contribution:		
		$= \frac{25}{100} \times (30000 + 50000)$	M1	
		$= 20000$	A1	
	(ii)	Ratio - Keya : Limo : Mumo		
		$= 30000:50000:20000$	M1	
		$= 3:5:2$	A1	
	(b)	Mumo's share of profit		
		$= \frac{2}{10} \times 25000$	M1	
		$= 5000$	A1	
	(c) (i)	$20000 + x = 80000 \times \frac{7}{8}$	M1	
		$x = 50000$	A1	
	(ii)	Mumo's % contribution in business during 2 nd year		
$= \frac{70000}{150000} \times 100$		M1	or $\frac{7}{15} \times 100\%$ M1	
	$= 46\frac{2}{3}\%$	A1	$= 46\frac{2}{3}\%$ A1	
		10		

18.	<p>(a) $1.54l = 1540 \text{ cm}^3$</p> <p>Volume = $\frac{22}{7} \times r^2 \times 10 = 1540$</p> $r = \sqrt{\frac{1540 \times 7}{22 \times 10}}$ $= 7$ <p>\therefore Diameter = $2 \times 7 = 14 \text{ cm}$</p> <p>(b) (i) Length of ribbon</p> $= 2 \times \frac{22}{7} \times 14 + 2 \times 2$ $= 88 + 4 = 92$ <p>(ii) Surface area covered by ribbon</p> $= 88 \times 1.5 = 132 \text{ cm}^2$ <p>(c) Surface area</p> $= \frac{22}{7} \times 49 + \frac{22}{7} \times 14 \times 10$ $= 154 + 440$ $= 594 \text{ cm}^2$	<p>B1</p> <p>M1</p> <p>A1</p> <p>M1</p> <p>M1</p> <p>A1</p> <p>B1</p> <p>M1</p> <p>M1</p> <p>A1</p> <hr/> <p>10</p>	<p>addition of the overlap</p>
-----	---	---	--------------------------------

19.	(a) Scale used:		
	9 cm represent 90 m	B1	
	\therefore scale 1:1000	B1	
	(b) (i) perimeter of homestead		
	$(2 \times 10) \times 4$	M1	
	$= 80 \text{ m}$	A1	
	(ii) Area of piece of land in ha.		
	$AB = 13.8 \times 10 = 138;$ $BC = 6 \times 10 = 60$		
	$\frac{\frac{1}{2}(60 + 90) \times 138}{10000}$	M1 M1	conversion to Hectares
	$= 1.035 \text{ ha}$	A1	
(c) \perp distance from centre of homestead to side CD shown	B1		
Distance, 3.6 cm, on map	B1		
Actual distance $3.6 \times 10 = 36 \text{ m}$	B1		
	10		

20.	<p>(a) Gradient of L_1</p> $= \frac{1 - -2}{6 - -3}$ $= \frac{1}{3}$ <p>equation of L_1</p> $= \frac{y - 1}{x - 6} = \frac{1}{3}$ $3y - 3 = x - 6$ $3y = x - 3$ $y = \frac{1}{3}x - 1$	M1									
	<p>(b) Gradient of L_2</p> $= \frac{-1}{\frac{1}{3}}$ $= -3$ <p>\therefore equation $\frac{y - 2}{x - -1} = -3$</p> $y = -3x - 1$ $\Rightarrow 3x + y + 1 = 0$	M1									
	<p>(c) equation of L_3</p> $\frac{y - 1}{x - 1} = -3$ $y - 1 = -3(x - 1)$ $y = -3x + 4$	M1									
	<p>x intercept: when $y = 0$, $x = \frac{4}{3}$ \therefore coordinates of x intercepts $(\frac{4}{3}, 0)$</p>	A1									
	<p>y intercept: when $x = 0$, $y = 4$ \therefore coordinates of y intercept $(0, 4)$</p>	A1									
		B1									
		B1									
		10									

21.

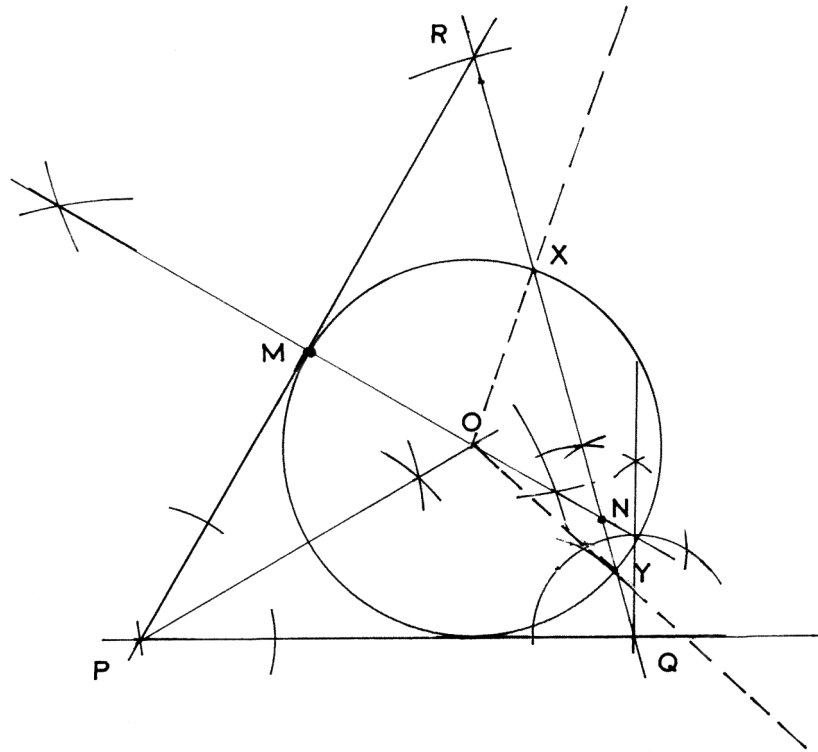

(a) Lines PQ and PR
 angle 75° constructed
 completion of $\triangle PQR$.

B1
B1
B1
B1

(b) (i) \perp bisector of PR
 (ii) angle bisector $\angle QPR$
 $\angle POM \ 60^\circ \pm 1^\circ$
 (iii) circle with radius OM
 $XY = 4.3 \pm 0.1$
 $\angle XOY \ 114^\circ \pm 1^\circ$

B1
B1
B1
B1
B1
B1
B1

10

22.	(a) (i)	$\frac{400\text{m}}{64\text{s}}$	M1		
		$= 6.25 \text{ m/s}$	A1		
	(ii)	speed during second lap			
		6.25×1.06 6.625 m/s	M1 A1		
	(b) (i)	total time for two laps			
		time for 2 nd lap = $\frac{400}{6.625}$	M1		
		$\simeq 60.38 \text{ s}$			
		total time $= 64 + 60.38$ $= 124.38 \text{ s}$	M1 A1		
		(ii) average speed in km/h			
	$\frac{800}{124.38} \text{ m/s}$	M1			
$= \frac{800}{124.38} \times \frac{3600}{1000}$	M1	✓ conversion			
$= 23.15 \text{ km/h}$	A1				
		10			

23.	(a) (i)	amount of money spent		
		$= \frac{420}{8} \times 20 + 50$	M1	
		$= 1100$	A1	
	(a) (ii)	number of bananas sold		
		$= 420 + \frac{420}{70} - 14$		
		$= 412$	B1	
	(b) (i)	s.p. of bananas		
		$= 1100 \times 1.6$	M1	
		$= 1760$		
		let x be number of bananas sold at sh 30		
		$\therefore \frac{x}{5} \times 30 + \frac{412-x}{3} \times 10 = 1760$	M1	
		$18x + 412 - 10x = 1760$	M1	
		$x = 145$	A1	
		(ii) No of bananas sold at sh 10		
$= 412 - 145 = 267$		B1		
Amount of money obtained				
$= \frac{267}{3} \times 10$	M1			
$= 890$	A1			
		10		

24.

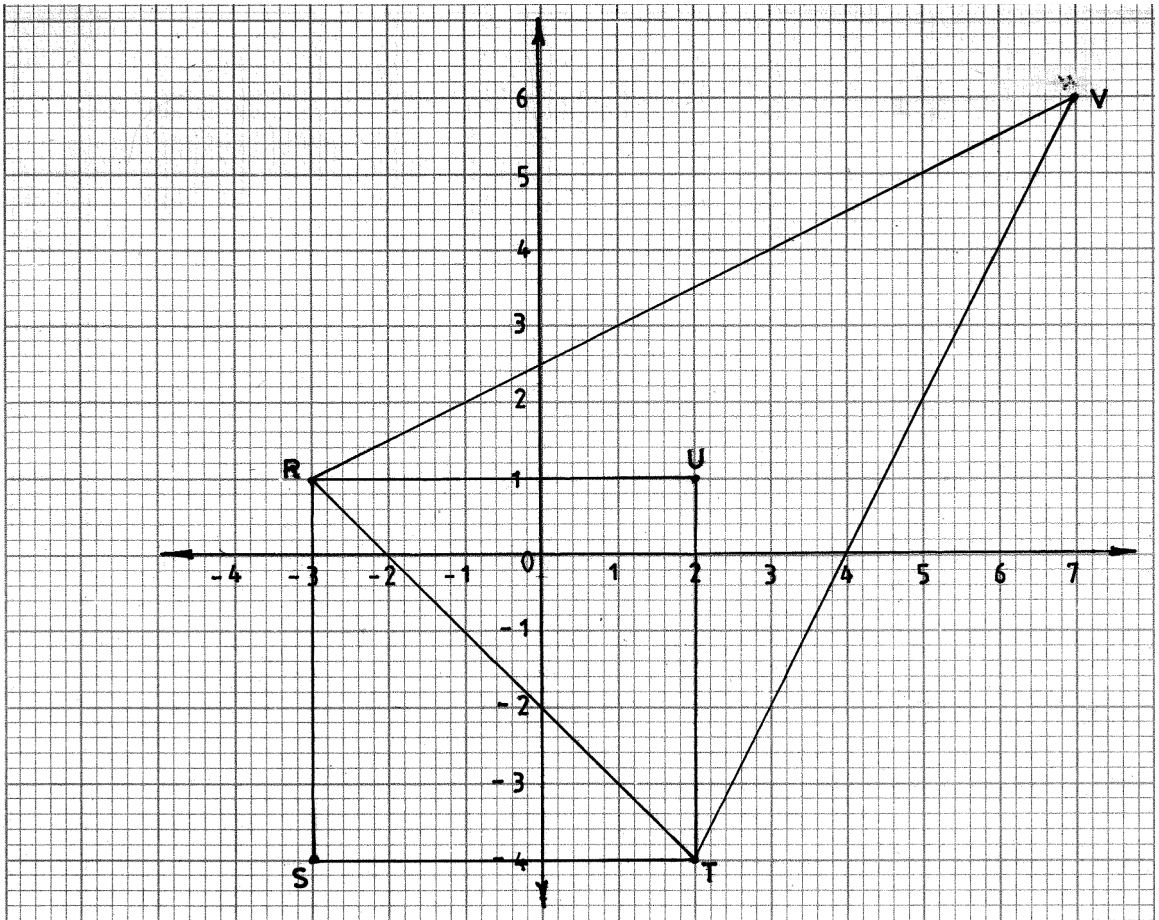

(a) (i) $\triangle RST$ ✓ drawn

B1

(ii) Area of $\triangle RST$: $\frac{1}{2} \times 5^2$
 $= 12.5$

M1
A1

(b) (i) Plotting point U
coordinates of point U (2, 1)

B1
B1

(ii) Plotting of point V
coordinates of point V (7, 6)

B1
B1

(c) Area of quadrilateral RSTV
diagonals $RT = \sqrt{50}$
and $SV = \sqrt{200}$

B1 for RT and SV

$$\therefore \text{Area} = \frac{1}{2} \times \sqrt{50} \times \sqrt{200}$$

M1

$$= \frac{1}{2} \times 5\sqrt{2} \times 10\sqrt{2}$$

$$= 50$$

A1

10

4.3.4 Mathematics Alternative B Paper 2 (122/2)

1.	$\frac{(0.214)^{1/2} - (0.38)^3}{(0.817)^{1/4}} = \frac{0.40772934}{0.950726313}$ $= 0.4289$	B1 B1	
		2	
2.	<p>(a) $\frac{ar^5}{ar^2} = \frac{5}{32} \times \frac{4}{5}$</p> $r^3 = \frac{1}{8} \Rightarrow r = \frac{1}{2}$ <p>(b) $ar^2 = \frac{5}{4}$</p> $a \times \left(\frac{1}{2}\right)^2 = \frac{5}{4} \Rightarrow a = \frac{5}{4} \times \frac{4}{1}$ $a = 5$	M1 A1 M1 A1	
		4	
3.	$\frac{1}{2} \times 4a \{3a + (3a + 3)\} = 60$ $2a(6a + 3) = 60$ $12a^2 + 6a - 60 = 0$ $2a^2 + a - 10 = 0$ $(2a + 5)(a - 2) = 0$ $a = 2 \text{ or } a = -\frac{5}{2}$ $a = 2$	M1 M1 A1	
		3	
4.	<p>Complete squares = 12</p> <p>Part squares = 20</p> $\text{Approx. area} = 12 + \frac{20}{2}$ $= 22$	B1 M1 A1	for 12 and 20
		3	

5.	$A = 48000 (1.05)^3$ $= 55\,566$ <p>Interest = 55 566 - 48 000</p> $= 7\,566$	M1 A1 B1 3	
6.	$3(4\hat{i} + 5\hat{j}) - 2(8\hat{i} - 3\hat{j}) = p\hat{i} + 3q\hat{j}$ $12\hat{i} + 15\hat{j} - 16\hat{i} + 6\hat{j} = p\hat{i} + 3q\hat{j}$ $-4\hat{i} + 21\hat{j} = p\hat{i} + 3q\hat{j}$ <p>$\therefore p = -4$</p> $3q = 21 \Rightarrow q = 7$	M1 M1 A1 3	for $-4\hat{i} + 21\hat{j}$ for both $p = -4$ and $q = 7$
7.	<p>In 1h A does $\frac{1}{8}$ of work</p> <p>B does $\frac{1}{10}$ of work</p> <p>In 3h both A and B do $3\left(\frac{1}{8} + \frac{1}{10}\right)$</p> $= \frac{27}{40} \text{ of work}$ <p>Remaining piece of work</p> $= 1 - \frac{27}{40}$ $= \frac{13}{40}$ <p>Time for A to complete the remaining work</p> $= \frac{13}{40} \div \frac{1}{8}$ $= 2\frac{3}{5} \text{ h}$	M1 M1 M1 A1 4	

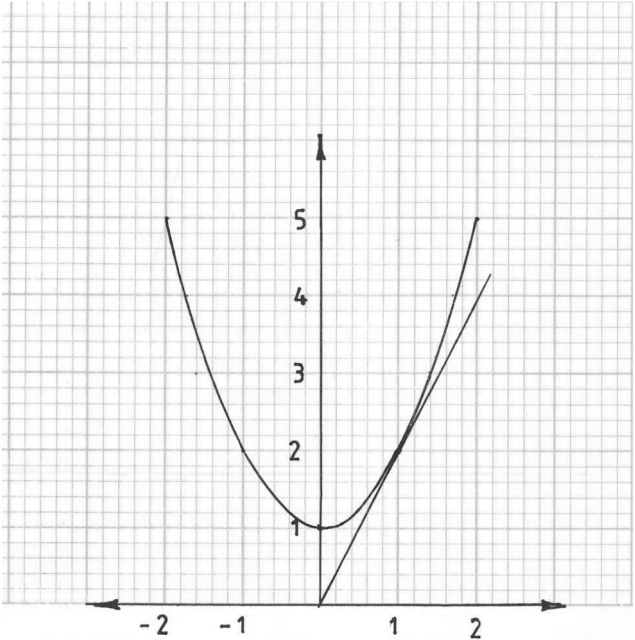
8.	 <p>tangent at A</p> $\text{gradient} = \frac{4 - 0}{2 - 0}$ $= 2$	B1 M1 A1	
		3	
9.	$\tan^{-1} \sqrt{3} = 60$ $2\theta - 30 = 60^\circ, 240^\circ, 420^\circ, 600^\circ$ $2\theta = 90^\circ, 270^\circ, 450^\circ, 630^\circ$ $\theta = 45^\circ, 135^\circ, 225^\circ, 315^\circ$	B1 B1 B1	
		3	
10.	<p>Longitude difference = $50^\circ + 22^\circ$</p> $= 72^\circ$ $\text{Distance} = \frac{72}{360} \times \frac{22}{7} \times 2 \times 6370$ $= 8008 \text{ km}$	M1 M1 A1	
		3	

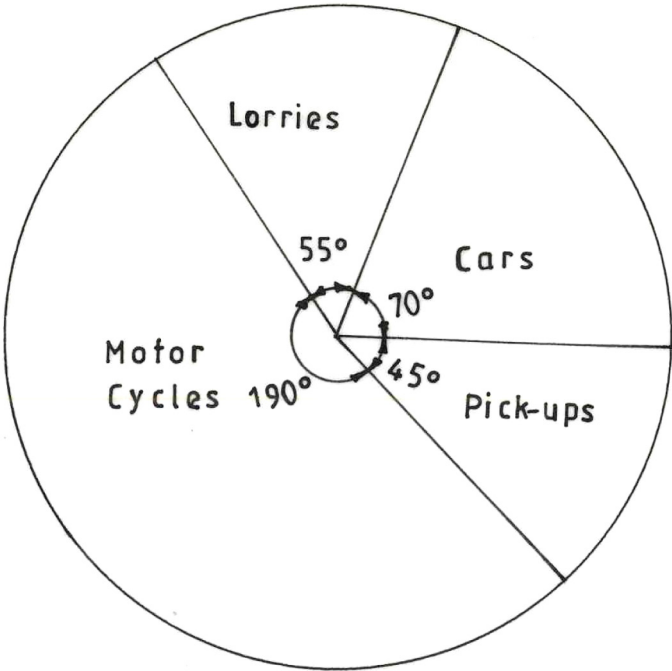
11.	$\det \begin{pmatrix} 8 & 3 \\ 4 & 2 \end{pmatrix} = 16 - 12 = 4$ $\text{Matrix N} = \frac{1}{4} \begin{pmatrix} 2 & -3 \\ -4 & 8 \end{pmatrix}$ $= \begin{pmatrix} \frac{1}{2} & -\frac{3}{4} \\ -1 & 2 \end{pmatrix}$	B1 M1 A1 3	
12.	$5x + 6y = 50$ $7x + 5y = 53$ $42x + 30y = 318$ $25x + 30y = 250$ $17x = 68$ $x = 4$ $20 + 6y = 50 \Rightarrow y = 5$	M1 M1 A1 B1 4	for both equations set
13.	Angle for: $\text{Cars} = \frac{14}{72} \times 360^\circ = 70^\circ$ $\text{Lorries} = \frac{11}{72} \times 360^\circ = 55^\circ$ $\text{Motor cycle} = \frac{38}{72} \times 360^\circ = 190^\circ$ $\text{Pick ups} = \frac{9}{72} \times 360^\circ = 45^\circ$ 	B2 B1 3	All angles correct (allow B1 for 3 correct)

14.	<p>Area scale factor = Det of matrix</p> $= \frac{4}{9} - 0$ $= \frac{4}{9}$ <p>Area of A'B'C'D' = $\frac{4}{9} \times 27$</p> $= 12 \text{ cm}^2$	M1	
		M1 A1	
		3	
15.	<p>(a)</p> <p>(b) Constant of proportionality =</p> $\text{Gradient} = \frac{24 - 12}{20 - 10} = 1.2$	<p>P1 ✓ plotting L1 ✓ line drawn</p> <p>B1 or equivalent</p>	
		3	

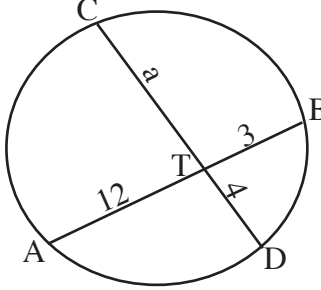
16.	<p>Let $CT = a$</p> $AT \cdot TB = CT \cdot TD$ $12 \times 3 = a \times 4$ $a = \frac{12 \times 3}{4}$ $= 9$ $CT : TD = 9:4$	<p>M1</p> <p>A1</p> <p>B1</p>	
			3
17.	<p>(a) (i) $40000 \times \frac{20.5}{100}$</p> $= 8200$ <p>(ii) total hire purchase price</p> $= 8200 + 12 \times 4800$ $= 65800$ <p>(iii) deposit as percentage of hire purchase price</p> $= \frac{8200}{65800} \times 100\%$ $= 12.46200608 = 12.5\%$ <p>(iv) h.p. price more than cash price</p> $= 65800 - 40000 = 25800$ <p>(b) Bidii's deposit as percentage of cash price</p> $= 65800 - (12 \times 4000)$ $= 17800$ $\%age = \frac{17800}{40000} \times 100\%$ $= 44.5\%$	<p>M1</p> <p>A1</p> <p>M1</p> <p>A1</p> <p>M1</p> <p>A1</p> <p>B1</p> <p>M1</p> <p>A1</p> <p>B1</p>	
			10

18.	<p>(a)</p> <p>(i) let number of pieces be n</p> $15 = 0.5 + (n - 1) \times 0.25$ $0.25n = 14.75$ $n = 59$ <p>(ii) length of 10th piece</p> $= 0.5 + (10 - 1)0.25$ $= 0.5 + 9 \times 0.25 = 2.75 \text{ m}$ <p>(iii) $S_{59} = \frac{59}{2} \{2 \times 0.5 + 58 \times 0.25\}$</p> $= 457.25 \text{ m}$ <p>(b)</p> $63 = \frac{n}{2} \{2 \times 0.5 + (n - 1)0.25\}$ $126 = n \{1 + 0.25n - 0.25\}$ $0.75n + 0.25n^2 = 126$ $n^2 + 3n - 504 = 0$ $(n + 24)(n - 21) = 0$ $n = -24 \text{ or } 21$ $n = 21$	<p>M1</p> <p>A1</p> <p>M1</p> <p>A1</p> <p>M1</p> <p>A1</p> <p>M1</p> <p>M1</p> <p>M1</p> <p>A1</p> <p>B1</p>	<p>or equivalent</p>
		10	

19. (a)

x	-6	-5	-4	-3	-2	-1	0	1	2	3
y	13	5	(-1)	-5	-7	-7	(-5)	-1	5	13

B2 (allow B1 for 5 values ✓)

(b) (i)

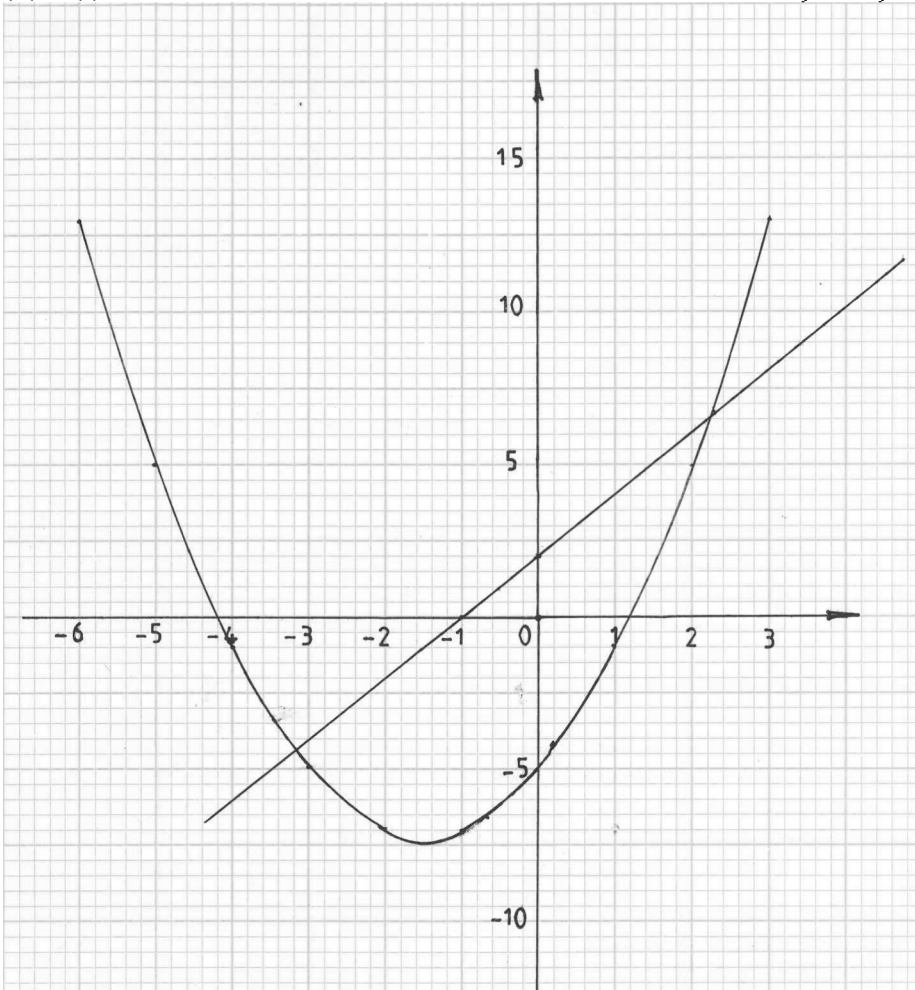

(ii) -4.2, 1.2

c(i)

(-3.2, -4.5)

(2.2, 6.5)

S1
P1
C1
B1
B1
L1
B1
B1

✓ coordinates

10

20. (a) The mean:

$$= \frac{2 \times 34.5 + 4 \times 44.5 + 10 \times 54.5 + 13 \times 64.5 + 14 \times 74.5 + 5 \times 84.5 + 2 \times 94.5}{50}$$

$$= \frac{3285}{50}$$

$$= 65.7$$

(b)

Marks	30-39	40-49	50-59	60-69	70-79	80-89	90-99
frequency	2	4	10	13	14	5	2
cf	2	6	16	29	43	48	50

B1

M1

A1

mid points for Σfx

B1

\sqrt{cfs}

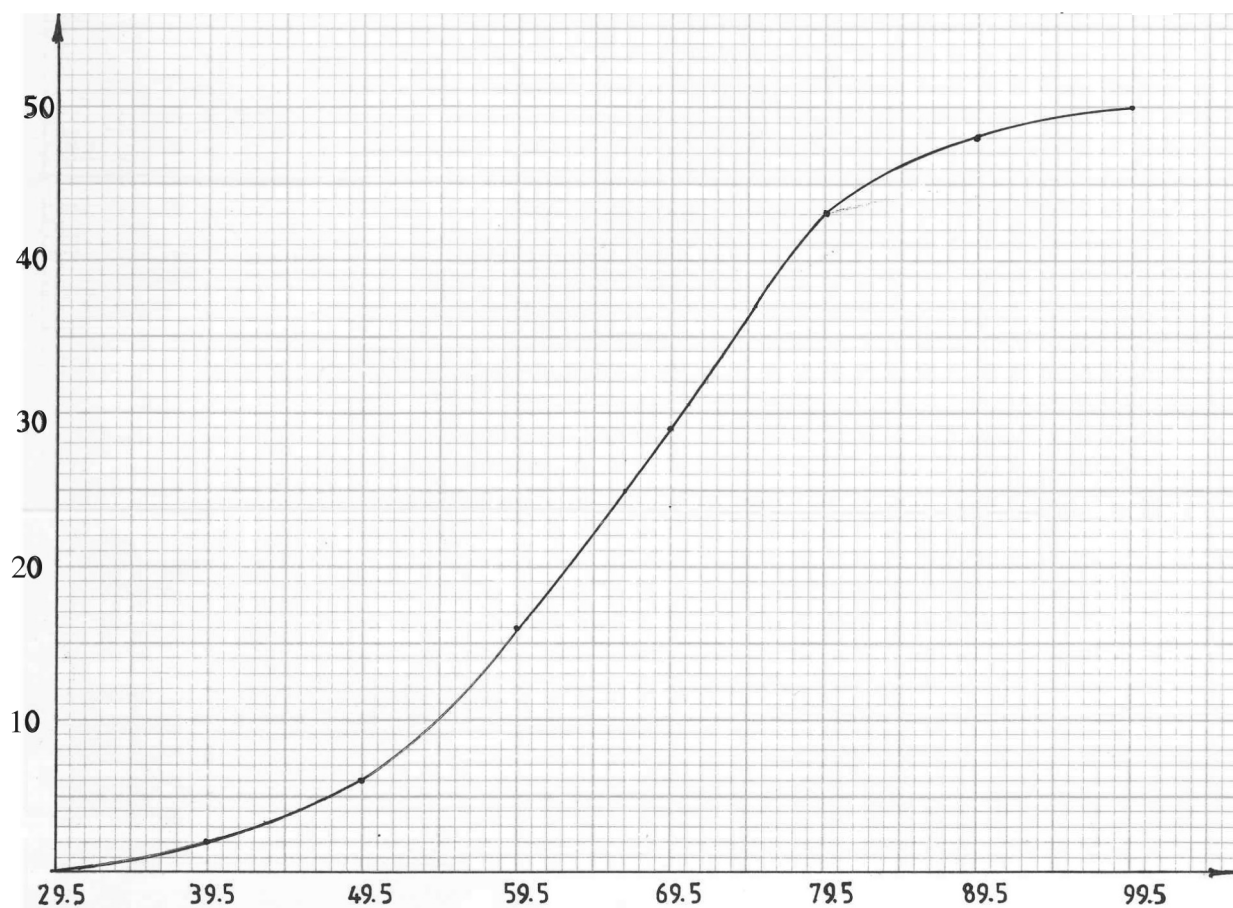

(c) (i) median : 66.5

(ii) position of student who scores 75 = 37th

S1
P1
C1

B1

B1

B1

25th pos for 66.5

10

21.	<p>(a) $AD = \sqrt{9.2^2 - 6^2}$</p> $= 7.0$ <p>(b) Angle ABD = $\cos^{-1} \frac{6}{9.2}$</p> $= 49.3^\circ$ <p>(c) $\frac{BC}{9.2} = \tan 40^\circ$</p> $BC = 9.2 \tan 40$ $= 7.7$ <p>(d) Area of ΔACD:</p> $\angle ADB = 90^\circ - 49.3^\circ = 40.7$ <p>Side DC: $\frac{9.2}{DC} = \cos 40^\circ$</p> $DC = \frac{9.2}{\cos 40^\circ} = 12 \text{ cm}$ <p>\therefore Area ΔACD</p> $= \frac{1}{2} AD \times DC \sin (40 + 40.7)$ $= \frac{1}{2} \times 7 \times 12 \times \sin 80.7$ $= 41.4 \text{ cm}^2$	M1 A1 M1 A1 M1 A1 B1 B1 M1 A1 10	
-----	---	--	--

22.	(a) P(Daudi uses a train and is punctual)		
	$= 0.3 \times 0.8$	M1	
	$= 0.24$	A1	
	(b) P(Daudi uses bus and is late for work)		
	$= 0.5 \times 0.3$	M1	
	$= 0.15$	A1	
	(c) P(Daudi punctual)		
	$= 0.3 \times 0.8 + 0.5 \times 0.7 + 0.2 \times 0.9$	M1	
	$= 0.24 + 0.35 + 0.18$		
	$= 0.77$	A1	
	(d) P(Daudi late)		
	$= 1 - 0.77$	M1	
	$= 0.23$	A1	
	(e) P(Daudi uses train or bus and is punctual)		
$= 0.3 \times 0.8 + 0.5 \times 0.7$	M1		
$= 0.59$	A1		
		10	

23.

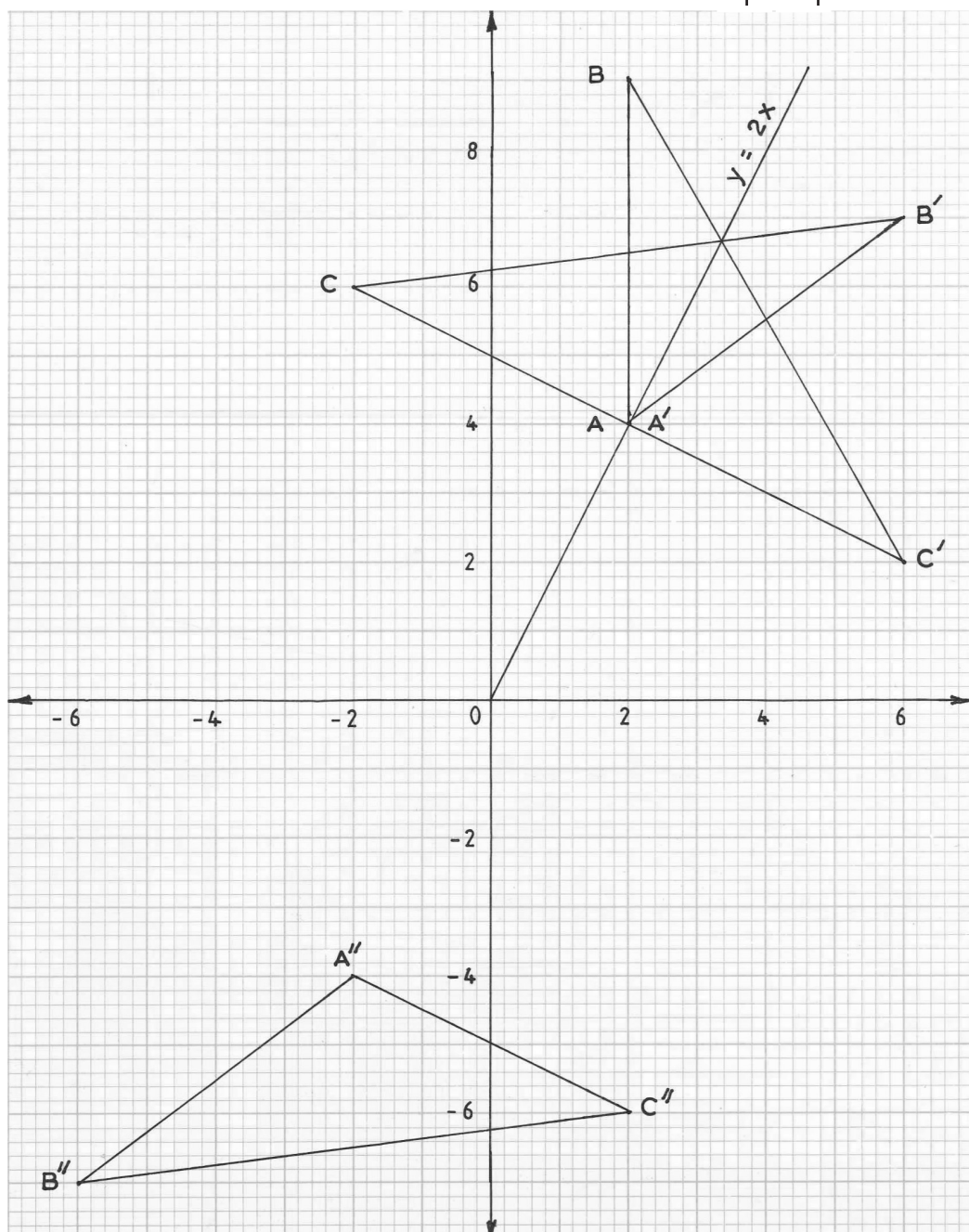

(a) (i)

$$(ii) \begin{pmatrix} -\frac{3}{5} & \frac{4}{5} \\ \frac{4}{5} & \frac{3}{5} \end{pmatrix} \begin{pmatrix} 2 & 2 & 6 \\ 4 & 9 & 2 \end{pmatrix} = \begin{pmatrix} 2 & 6 & -2 \\ 4 & 7 & 6 \end{pmatrix}$$

(b) Reflection in line $y = 2x$

(c) (i)

$$(ii) \text{ matrix of } H = \begin{pmatrix} -1 & 0 \\ 0 & -1 \end{pmatrix}$$

$$(d) HT = \begin{pmatrix} -1 & 0 \\ 0 & -1 \end{pmatrix} \begin{pmatrix} -\frac{3}{5} & \frac{4}{5} \\ \frac{4}{5} & \frac{3}{5} \end{pmatrix} = \begin{pmatrix} \frac{3}{5} & -\frac{4}{5} \\ -\frac{4}{5} & -\frac{3}{5} \end{pmatrix}$$

B1 ΔABC drawn

M1

A1

B1 $\Delta A'B'C'$ \checkmark drawn

B1 reflection

B1 equation $y = 2x$ B1 $\Delta A''B''C''$ \checkmark drawn

B1

M1 or equivalent

A1

10

24.

Dr			Cr		
Date 2014	Particulars	Sh Cts	Date 2014	Particulars	Sh Cts
January			January		
1	Balance	3250.00	3	Oranges	9000.00
5	Orange	11750.00	4	Pawpaw	1650.00
6	Pawpaw	1812.50	4	Vegetables	700.00
6	Vegetable	1140.00	4	Transport	200.00
			8	Market fees	150.00
			10	Wages	400.00
			11	Balance	5852.50
		17952.50			17952.50

Oranges sales = 11750.00
 Pawpaw sales = 1812.50
 Oranges purchase = 9000.00
 Pawpaw purchase = 1650.00
 all other entries correct

Totals

Dr/Cr columns = 17952.50

Balance on 11/01/2011

= Sh 17952.50 - (900 + 1650 + 700 + 200 + 150 + 400)

= 5852.50

B1
 B1
 B1
 B1
 B2

M1
 A1

M1
 A1

10